

DM Series Nd:YLF UV Nanosecond Lasers

www.photonix.com

Photonics Industries' DM Series Nd:YLF UV nanosecond lasers combine remarkably high pulse energies (up to 40 mJ) within a simple, rugged, and efficient form factor. Dual Head configurations can go up to 80 mJ of pulse energy. The laser design ideally fulfills the needs of both research and industry, from pumping, to providing the necessary high energy for laser thermal processing or annealing applications in an industrial, compact form factor.



Applications

- High pulse energy cutting, drilling, welding, marking, patterning
- Laser Lift-Off (LLO) Systems, Debonding, Separation of Thin-film Semiconductor Materials
- Laser Thermal Processing (LTP)
Annealing, Laser Heat-tempering Metal Marking, Laser Discoloration & Bleaching Plastic Marking
- Semiconductor Lithography Systems/Photolithography

Features

- Exceptional high pulse energy UV laser:
Up to 40 mJ, Nd:YLF
- Two fully independent lasers, integrated into a Dual Head configuration available. Contact us.
Up to 80 mJ, UV Nd:YLF
- Exceptional repetition rate control:
Single shot up to 5 kHz

Specifications – DM Series High Pulse Energy Nanosecond Lasers, Nd:YLF UV Models

UV Models	DM1-351-20	DM1-351-30	DM1-351-40
Beam and output specifications			
Wavelength	351 nm		
Average power ¹	30 W at 3 kHz	40 W at 3 kHz	80 W at 2 kHz
Pulse energy	20 mJ at 1 kHz	30 mJ at 1 kHz	40 mJ at 2 kHz
Pulse width	~100 ns at 1 kHz		
Pulse repetition rate ²	Single shot to 5 kHz		2 to 5 kHz
Pulse-to-pulse stability ³	< 1.2% rms		
Long term power stability ⁴	< 0.5% rms		
Beam spatial mode ⁵	Multimode, M ² 10 to 14		
Beam pointing stability	< 25 μ rad		
Beam divergence	< 8 mrad		
Beam roundness	> 85%		
Beam diameter, at exit	~3 mm, nominal		
Polarization ratio	Horizontal; 100:1		
Operational specifications and system characteristics			
Interface	RS232, Ethernet, Software GUI, External TTL Triggering		
Warm-up time	< 5 minutes from standby, or cold start		
Electrical requirement	100-240 V AC		200-240 V AC
Line frequency	50-60 Hz		
Ambient temperature	Ambient 15°C to 30°C (59°F to 86°F) Operating Range, Relative Humidity 90% Max., non-condensing		
Power consumption ⁶	0.8 kW	1 kW	1.75 kW
Laser head Dimensions (LxWxH)	26 x 9.5 x 4.25 in		26 x 11 x 4.25 in
Power supply Dimensions (LxWxH) ⁷	15 x 10.2 x 3.5 in		16 x 16.2 x 3.5 in
Cooling system	Water-cooled		

- Higher average powers available in a Dual Head configuration. Contact us.
- Lower pulse repetition rates (down to < 1 kHz) performance achieved by pulse energy capping
- Measured at ambient temperature \pm 2°C
- Measured over 8 hours \pm 1°C
- TEM₀₀ beam option available. Contact us.
- Power consumption data does not include an external chiller's power consumption
- Total width with rack mount option is 19 in. Please note height in rack units is 2U.

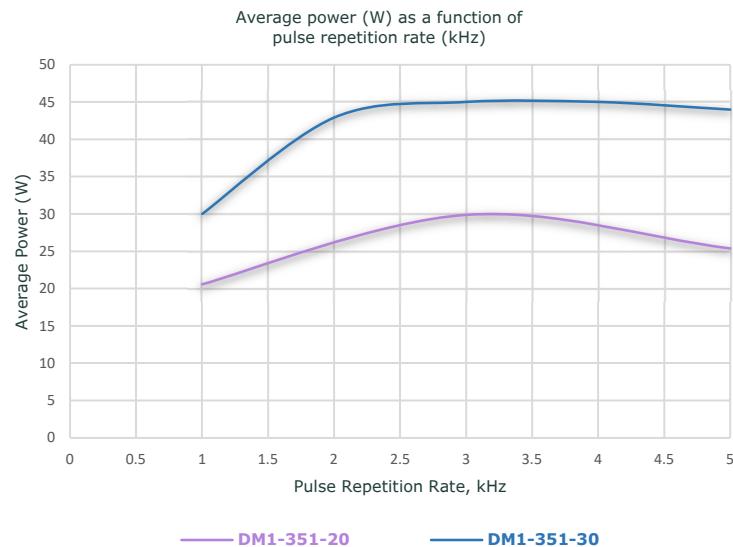

Dimensional Drawings

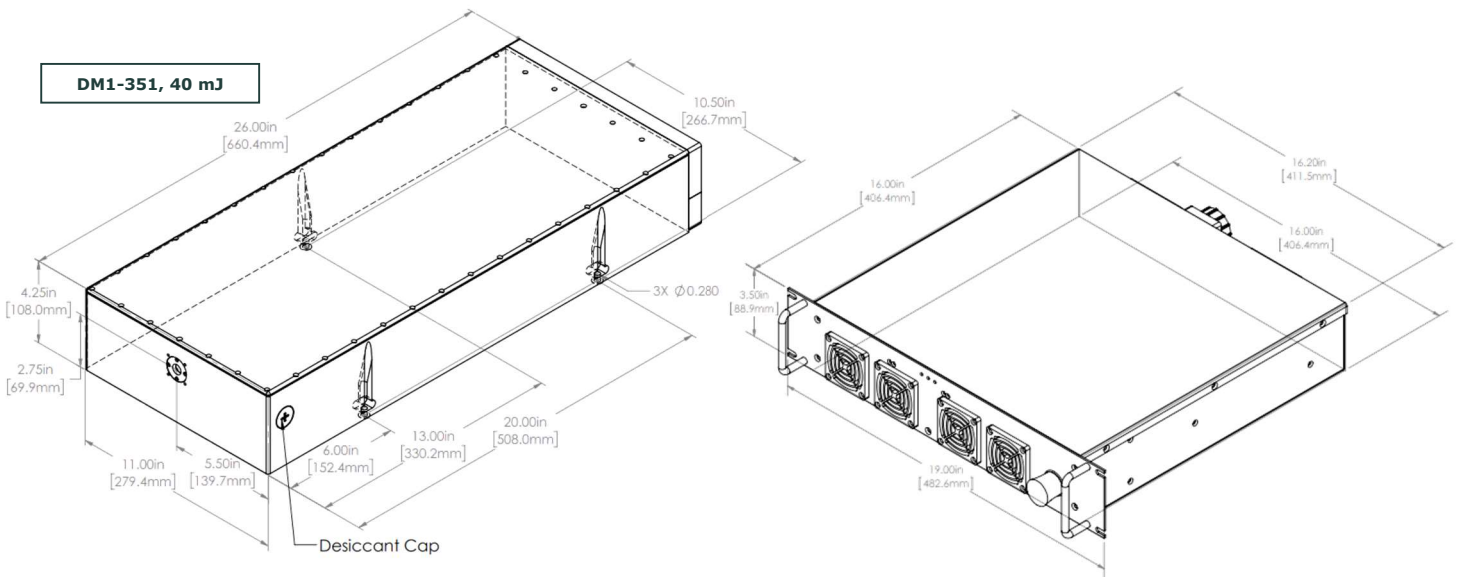
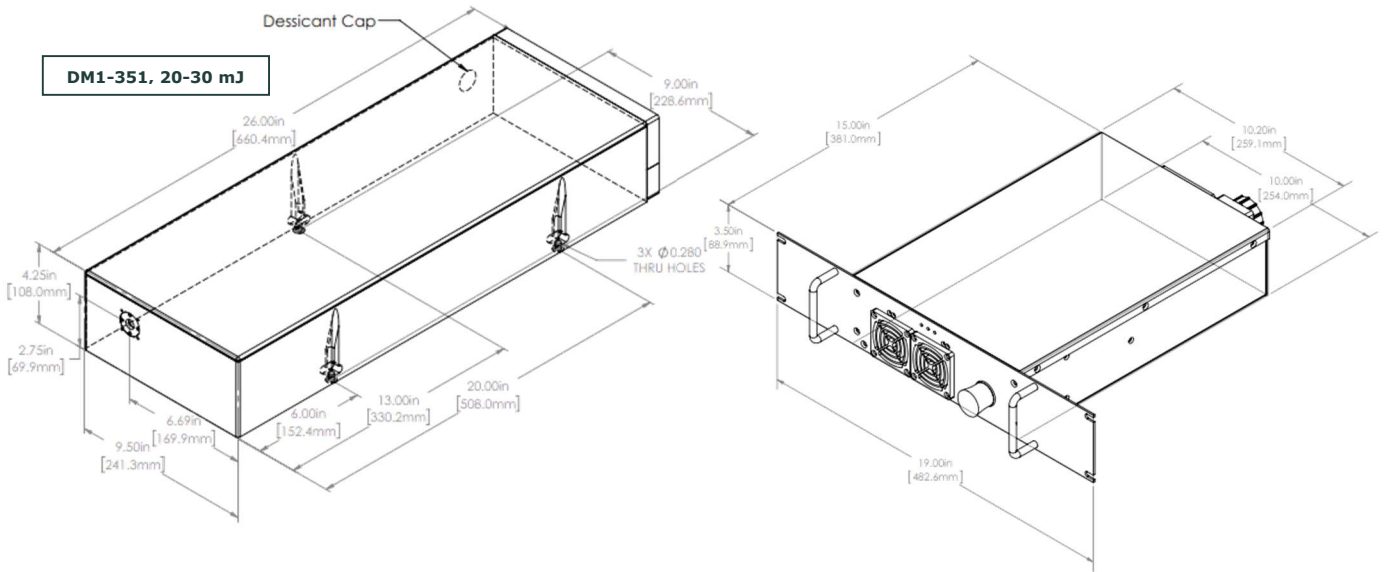

Photonics Industries DM Series nanosecond lasers have a separate external power supply box, no longer requiring an external controller or utility module. The RF driver is located in the laser head, and all control electronics and connections for operation and control of the laser can be found on the back panel of the compact laser head.

Product specifications, characteristics, and dimensional drawings are subject to change without notice.

Photonics Industries conforms to provisions of US 21 CFR 1040.10 & 1040.11 and is made under one or more US patents listed below: 9,531,147, 8,817,831, 7,869,471, 7,346,092, 7,082,149, 7,079,557, 6,999,483, 6,980,574, 6,961,355, 6,842,293, 6,762,405, 6,690,692, 6,587,487, 6,584,134, 6,366,596, 6,356,578, 6,327,281, 6,246,707, 6,229,829, 6,108,356, 6,061,370, 6,028,620, 5,936,983, 5,898,717 and Pending Patents

Copyright © 2022 by Photonics Industries International, Inc.

Main Headquarters: 1800 Ocean Ave, Ronkonkoma, New York 11779, United States

Photonics Industries International is the pioneer of intracavity harmonic lasers and is at the forefront of developing, manufacturing and marketing a wide range of nanosecond, sub-nanosecond, picosecond and femtosecond lasers for industrial, scientific, defense, and medical industries. Check out our products and see how we can help you apply our lasers to your needs.

[Website](#) - [Products](#) - [Applications](#) - [Company](#) - [Contact](#) - [International Network](#)

